

HILLIARD BRAKE SYSTEMS



Hilliard

SAFETY. RELIABILITY. PERFORMANCE.

BRAKE TYPE:
M200
 HYDRAULIC



The **Hilliard M200** brake caliper is a hydraulic applied, spring retracted brake caliper for use in heavy duty industrial applications. The brake comes standard with marine grade epoxy paint suitable for extreme environments. The M200 brake caliper is capable of producing a maximum 5,000 lbf of braking force at 1600 psi. Positive retraction mechanism maintains consistent air gap throughout the life of the brake pads.

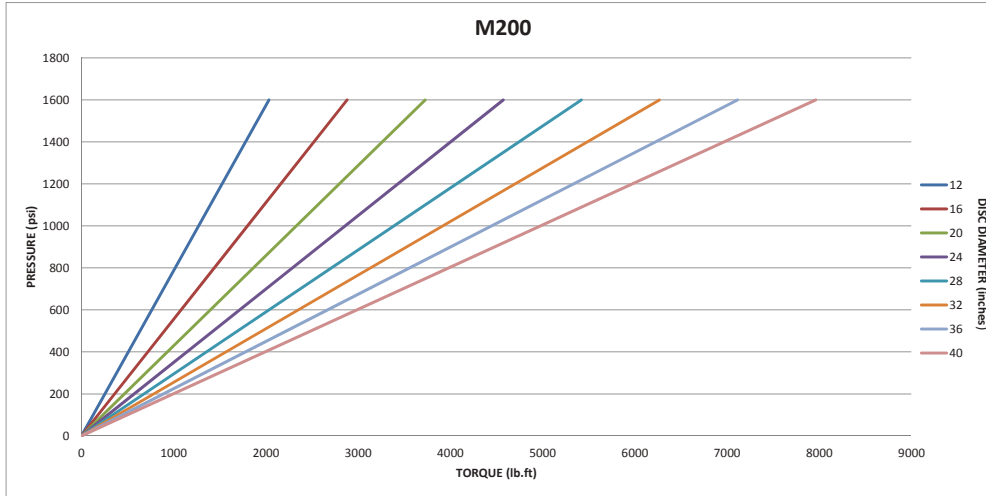
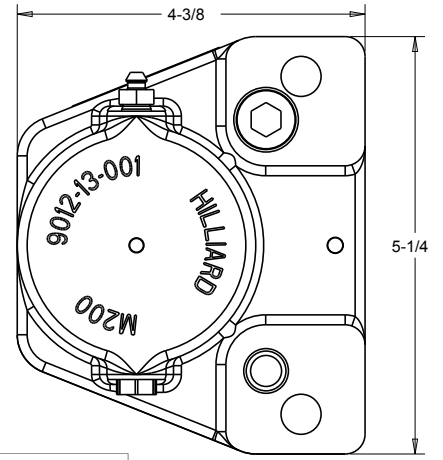

INDUSTRIES/APPLICATIONS:

- HYDRO TURBINES
- ELECTRIC GENERATORS
- MARINE PROPULSION
- WINCHES
- DYNAMOMETERS
- NUCLEAR COOLING PUMPS

BRAKE TYPE:
M300
 HYDRAULIC



The **Hilliard M300** brake caliper is a hydraulic applied, spring retracted brake caliper for use in heavy duty industrial applications. The brake comes standard with marine grade epoxy paint suitable for extreme environments. The M300 brake caliper is capable of producing a maximum 10,600 lbf of braking force at 1600 psi. Positive retraction mechanism maintains consistent air gap throughout the life of the brake pads.

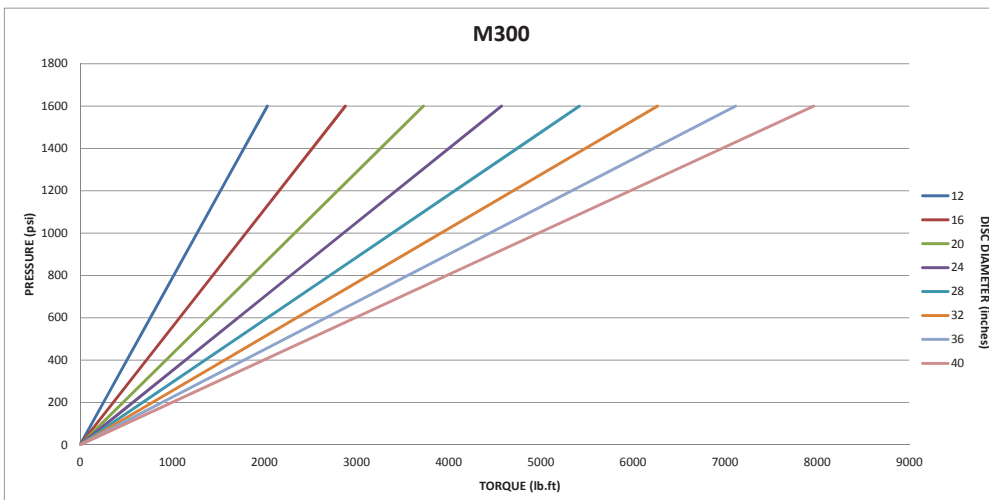
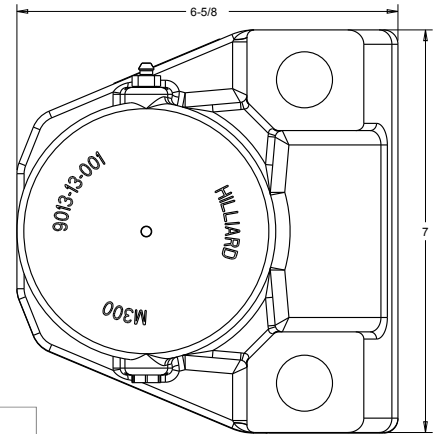

INDUSTRIES/APPLICATIONS:

- HYDRO TURBINES
- ELECTRIC GENERATORS
- MARINE PROPULSION
- WINCHES
- DYNAMOMETERS
- FRICTION WELDERS

All dimensions are nominal in inches.

BRAKE TYPE:
M400 HS
 HYDRAULIC APPLIED/
 SPRING RELEASED



The **Hilliard M400HS** brake caliper is a hydraulic applied, spring retracted brake caliper for use in heavy duty industrial applications. The brake comes standard with marine grade epoxy paint suitable for extreme environments. The M400HS brake caliper is capable of producing a maximum 12,960 lbf of braking force at 1800 psi. Positive retraction mechanism maintains consistent air gap throughout the life of the brake pads.

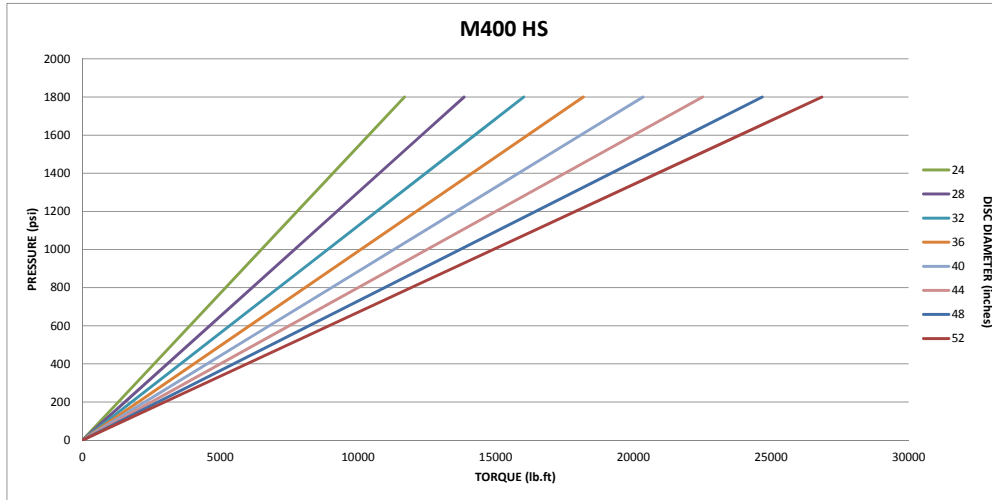
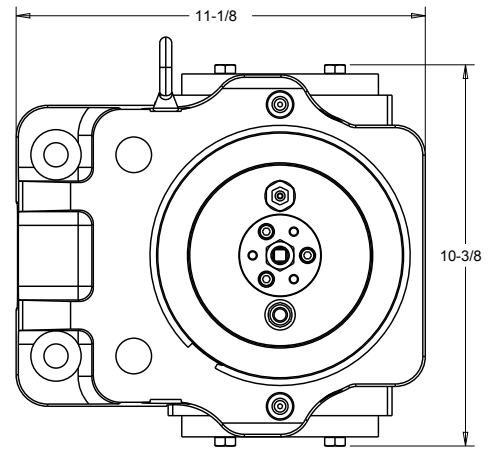

INDUSTRIES/APPLICATIONS:

- CRANE BRIDGE DRIVES
- WINCHES
- THEATRICAL/STAGE EQUIPMENT
- MARINE PROPULSION

INDUSTRIES/APPLICATIONS:

- CRANE HOISTS
- MINE HOISTS
- ELEVATORS
- ESCALATORS
- MARINE PROPULSION
- MINING CONVEYORS
- THEATRICAL/STAGE EQUIPMENT

BRAKE TYPE:
M400 SH
 SPRING-APPLIED/
 HYDRAULIC RELEASED

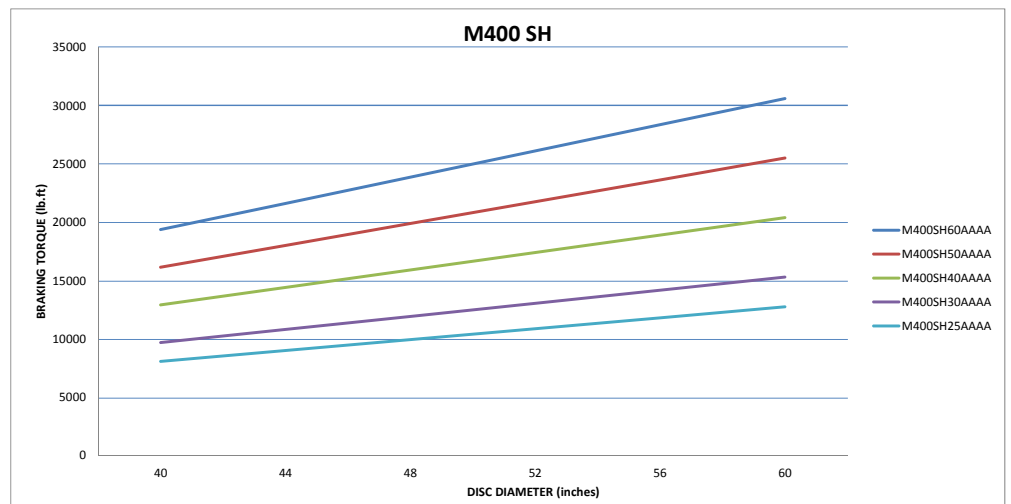
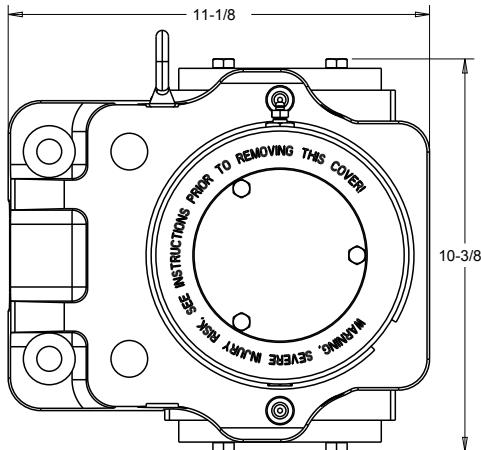

Max Torque Values at Zero PSI Pressure

The **Hilliard M400SH** brake caliper is a spring applied, hydraulically released brake for use in heavy duty industrial applications. The brake comes standard with marine grade epoxy paint suitable for extreme environments. The M400SH is available with standard force ratings which when paired with the correct disc size produces an exact braking torque for the application. The caliper features "Maintenance Mode" which removes all stored spring energy within the cylinder assembly. This allows for brake pad replacement, monitor unit adjustment and seal replacement without the need to remove the brake from service.

All dimensions are nominal in inches.

BRAKE TYPE:

M500 HS

HYDRAULIC APPLIED/
SPRING RELEASED



The **Hilliard M500HS** brake caliper is a hydraulic applied, spring retracted brake caliper for use in heavy duty industrial applications. The brake comes standard with marine grade epoxy paint suitable for extreme environments. The M500HS brake caliper is capable of producing a maximum 27,000 lbf of braking force at 1600 psi on the M500HS. Positive retraction mechanism maintains consistent air gap throughout the life of the brake pads.

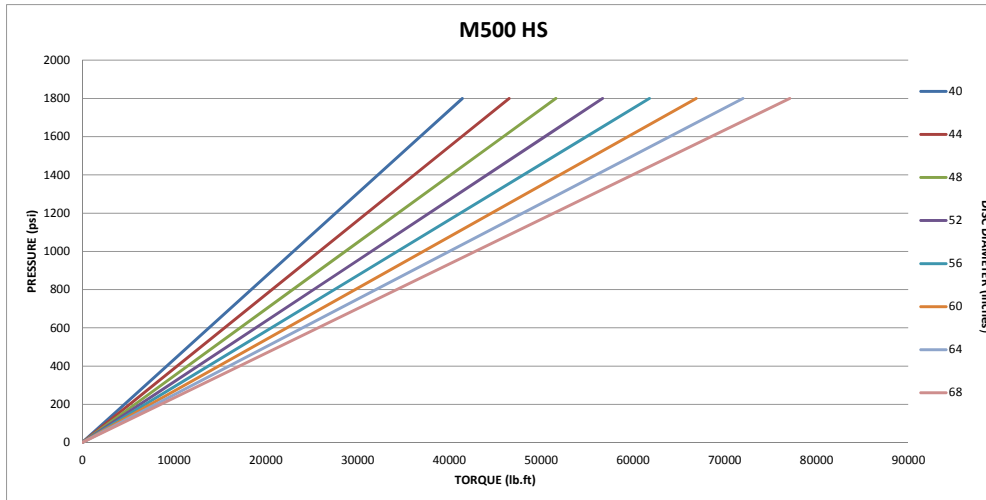
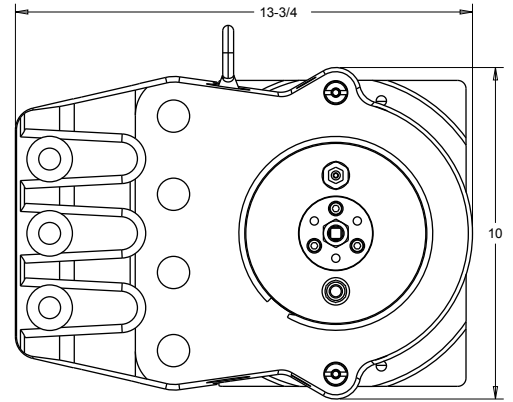

INDUSTRIES/APPLICATIONS:

- STAGE EQUIPMENT
- WINCHES
- MARINE PROPULSION

BRAKE TYPE:

M500 SH

SPRING-APPLIED/
HYDRAULIC RELEASED



The **Hilliard M500SH** brake caliper is a spring applied, hydraulically released brake for use in heavy duty industrial applications. The brake comes standard with marine grade epoxy paint suitable for extreme environments. The M500SH is available with standard force ratings which when paired with the correct disc size produces an exact braking torque for the application. The caliper features "Maintenance Mode" which removes all stored spring energy within the cylinder assembly.

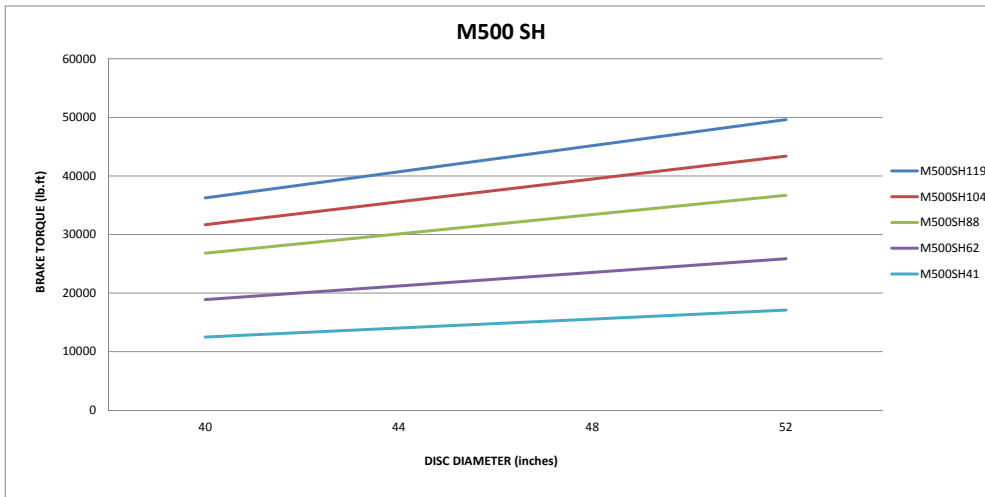
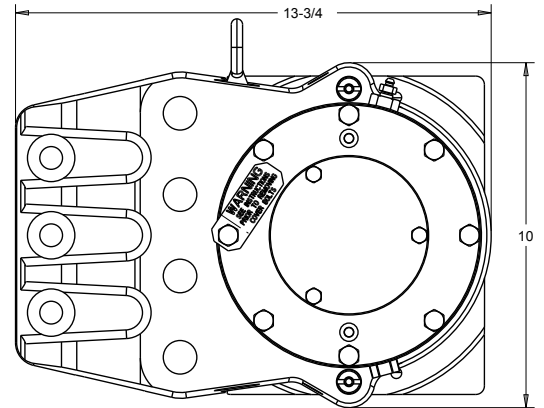

This allows for brake pad replacement, monitor unit adjustment and seal replacement without the need to remove the brake from service.

INDUSTRIES/APPLICATIONS:

- CONVEYORS
- MINE HOISTS
- STAGE EQUIPMENT
- CRANES
- CAR SHREDDERS
- THEATRICAL/STAGE EQUIPMENT

All dimensions are nominal in inches.

BRAKE TYPE:

M700 SH

SPRING-APPLIED/
HYDRAULIC RELEASED

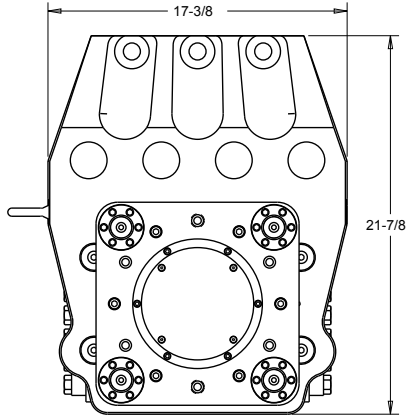

The **Hilliard M700SH** brake caliper is a spring applied, hydraulically released brake for use in heavy duty industrial applications. The brake comes standard with marine grade epoxy paint suitable for extreme environments. The M700SH is available with standard force ratings which when paired with the correct disc size produces an exact braking torque for the application. The caliper features "Maintenance Mode" which removes all stored spring energy within the cylinder assembly. This allows for brake pad replacement, monitor unit adjustment and seal replacement without the need to remove the brake from service. Engineered fasteners eliminate the need for special tools such as torque multipliers or hydraulic tensioners.

INDUSTRIES/APPLICATIONS:

CONVEYORS
MINE HOISTS
THEATRICAL/STAGE EQUIPMENT
CRANES

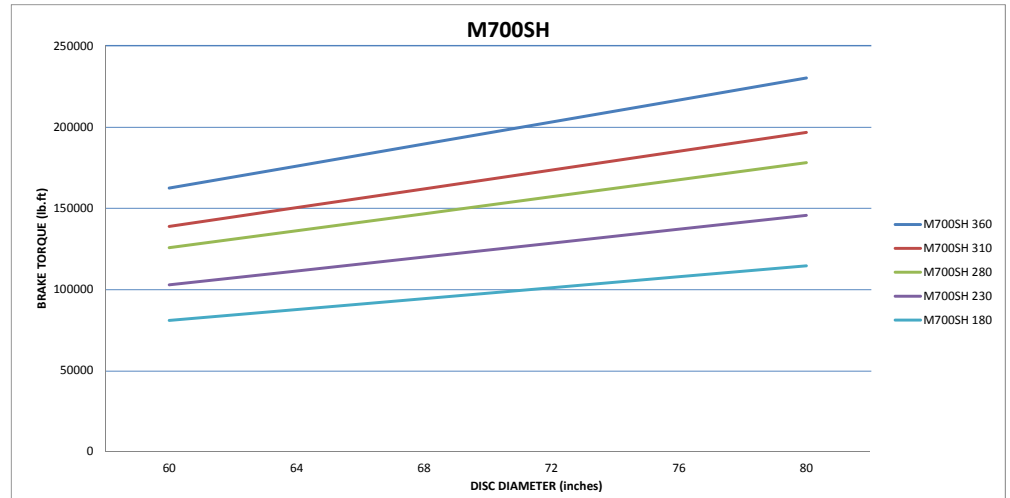

All dimensions are nominal in inches.

BRAKE TYPE:

M900 SH

SPRING-APPLIED/
HYDRAULIC RELEASED

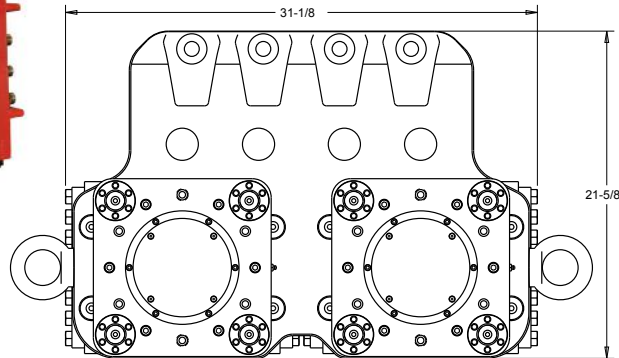

The **Hilliard M900SH** brake caliper is a floating spring applied, hydraulically released brake for use in heavy duty industrial applications. The brake comes standard with marine grade epoxy paint suitable for extreme environments. The M900SH is capable of producing 162,000 lbf of braking force. The floating design can accommodate up to 3/4 inch of axial movement due to thermal expansion of large equipment such as grinding mills and kilns. The caliper features "Maintenance Mode" which removes all stored spring energy within the cylinder assembly. This allows for brake pad replacement, monitor unit adjustment and seal replacement without the need to remove the brake from service. Engineered fasteners eliminate the need for special tools such as torque multipliers or hydraulic tensioners.

INDUSTRIES/APPLICATIONS:

GRINDING MILLS
MINE HOISTS
KILNS
THEATRICAL/STAGE EQUIPMENT

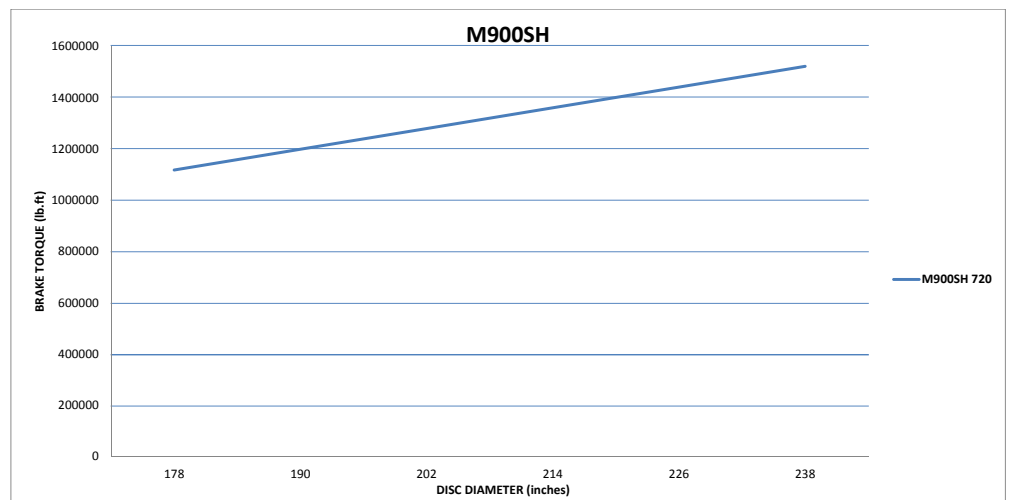

Caliper Brakes

PNEUMATIC APPLIED / SPRING RELEASED

A300

The **A300** is an arm style caliper brake designed to accept a large selection of Hilliard thrusters. The A300 requires a minimum disc diameter of 12" and is offered in 4 sizes to accommodate a 1/2", 1", 1-3/16", and 1-1/2" thick disc. The design of the caliper allows the user to quickly convert between right and left handed designs eliminating the need for multiple part numbers.

BRAKE TYPE:

A300-T200 AS

INDUSTRIES/APPLICATIONS:

GENERAL MACHINERY
PAPER MILLS
TEXTILE MACHINERY



Max Braking Force 950 lbf @ 80 psi

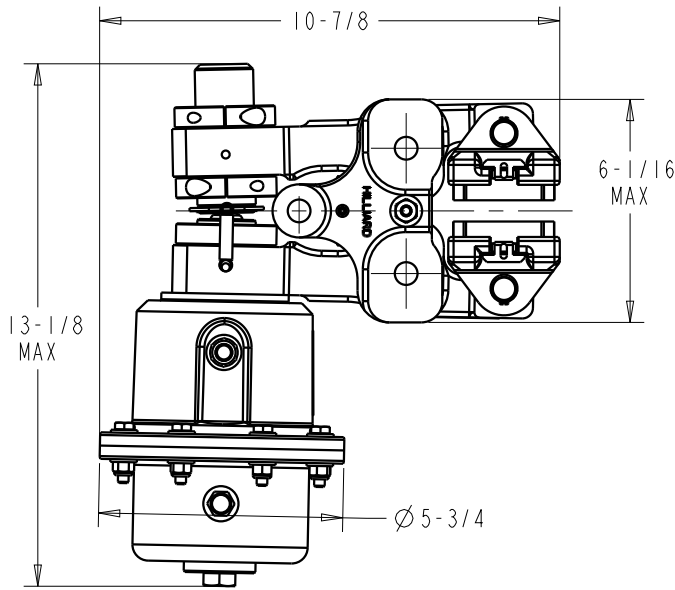

A300-T200 AS

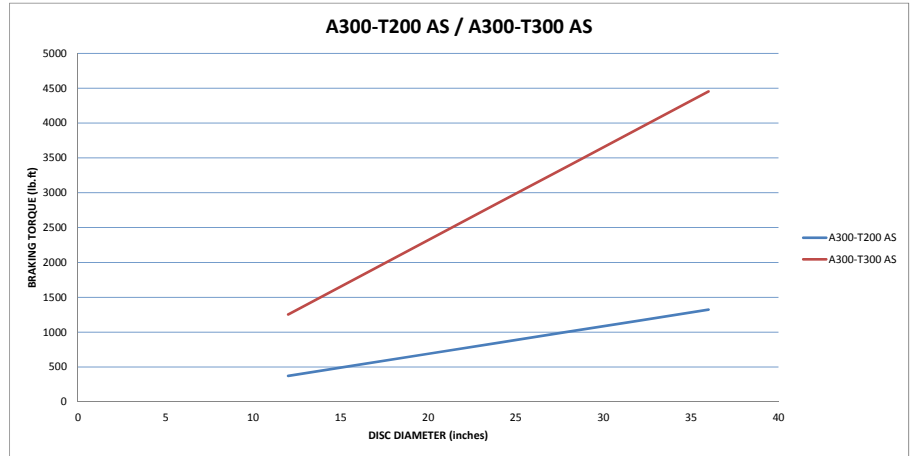
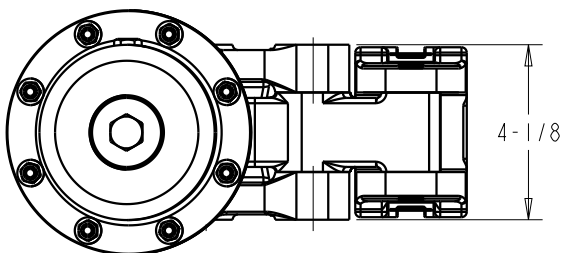

BRAKE TYPE:

A300-T300 AS

INDUSTRIES/APPLICATIONS:

GENERAL MACHINERY
PACKAGING MACHINERY
PAPER MILLS
TEXTILE MACHINERY



Max Braking Force 3200 lbf @ 66 psi

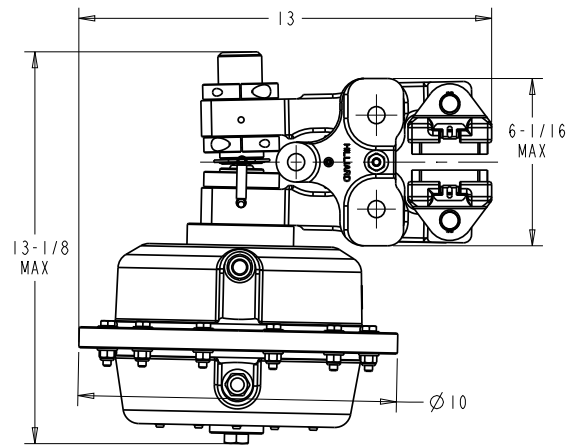

A300-T300 AS

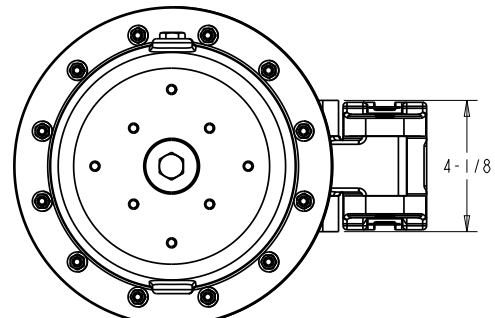

All dimensions are nominal in inches.

A400

The **A400** is an arm style caliper brake designed to accept a large selection of Hilliard thrusters. The 400 requires a minimum disc diameter of 24" and is offered in 2 sizes to accommodate a 1" and 1-1/2" thick disc. The design of the caliper allows the user to quickly convert between right and left handed designs eliminating the need for multiple part numbers.

BRAKE TYPE: A400-T400 AS

INDUSTRIES/APPLICATIONS:

MARINE
GENERAL MACHINERY
POWER PLANT FANS

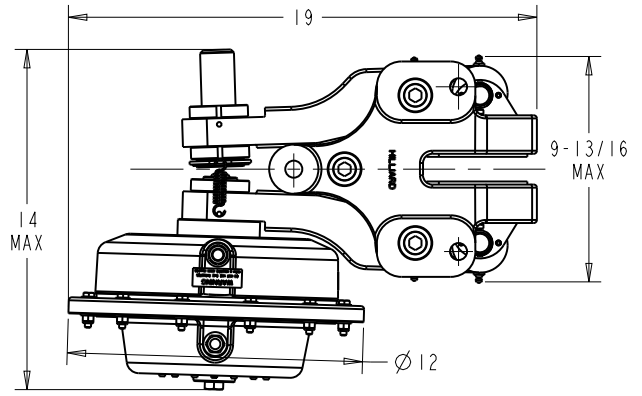

A400-T400 AS

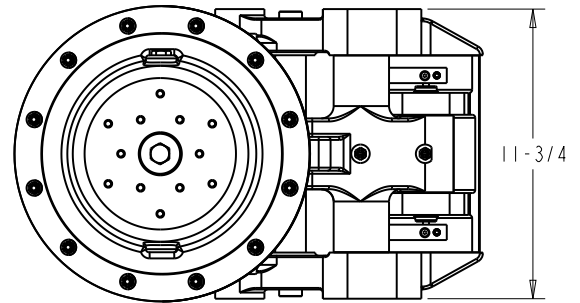

Max Braking Force 8400 lbf @ 67 psi

(This thruster is only to be used on the A400 caliper)

AS Thruster

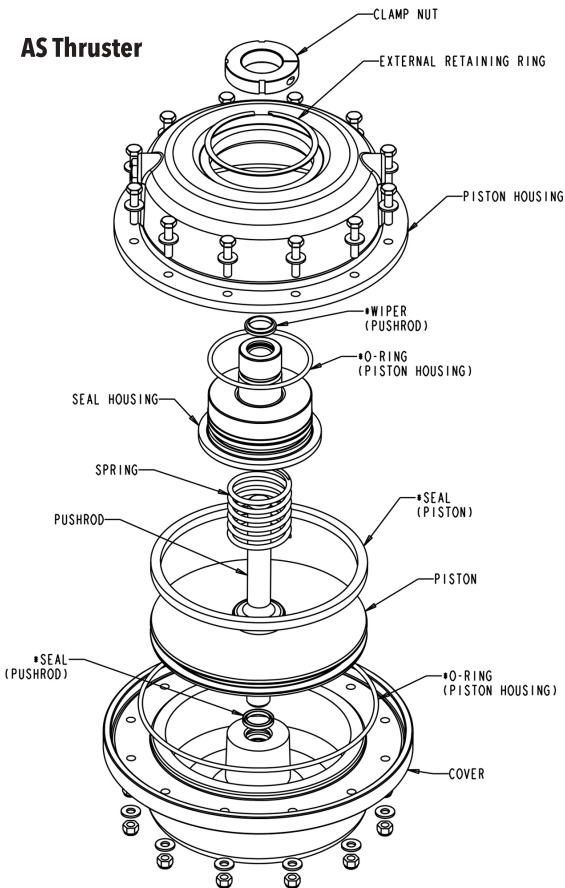

* RECOMMENDED SPARE PART (SEALS & O-RINGS AVAILABLE AS A KIT)

AS Thrusters

The AS thruster is a direct applied thruster that is pneumatically applied spring released. The Pneumatic applied thrusters are offered in multiple sizes to meet the needs of our customers.

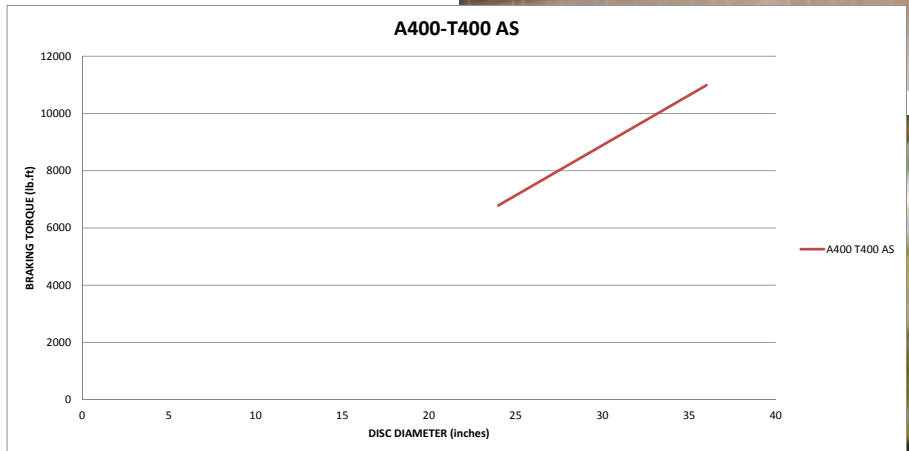

All dimensions are nominal in inches.

Caliper Brakes

SPRING-APPLIED/PNEUMATIC RELEASED

A300

The **A300** is an arm style caliper brake designed to accept a large selection of Hilliard thrusters. The A300 requires a minimum disc diameter of 12" and is offered in 4 sizes to accommodate a 1/2", 1", 1-3/16", and 1-1/2" thick disc. The design of the caliper allows the user to quickly convert between right and left handed designs eliminating the need for multiple part numbers.

BRAKE TYPE:

A300-T200 SA

INDUSTRIES/APPLICATIONS:

GENERAL MACHINERY
PAPER CONVERTING
WIRE PAYOFFS
STEEL PROCESSING LINES
AMUSEMENT RIDES

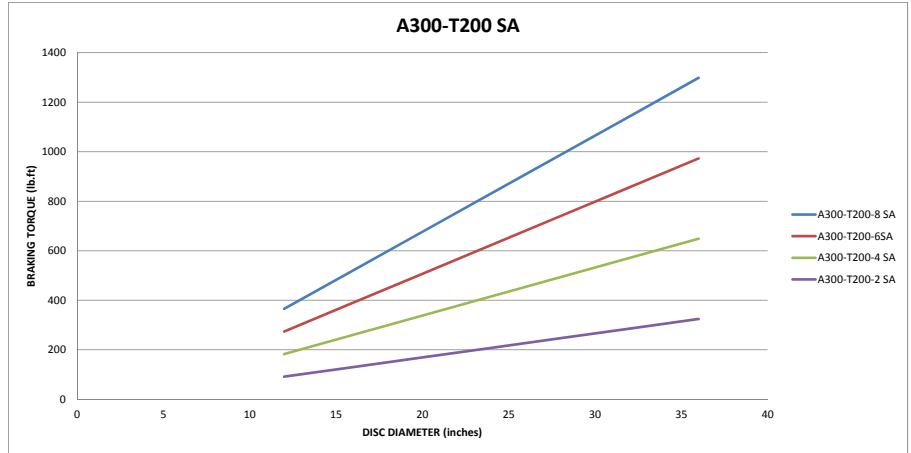

BRAKE TYPE:

A300-T300 SA

INDUSTRIES/APPLICATIONS:

GENERAL MACHINERY
MATERIAL HANDLING
STEEL PROCESSING LINES



Max Braking Force 930 lbf @ 0 psi

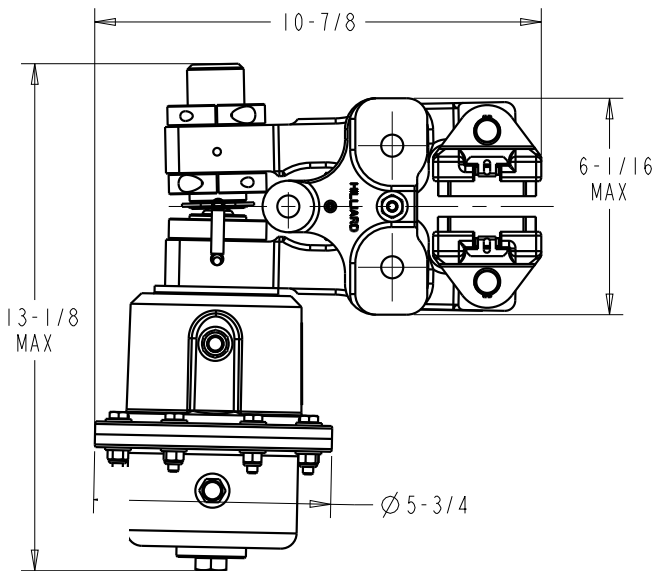

A300-T200 SA

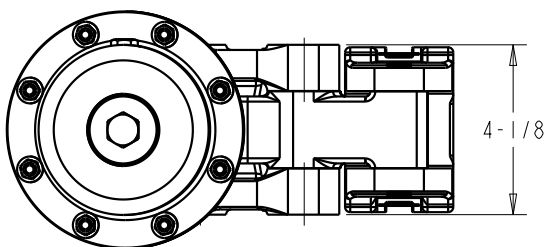

Max Braking Force 3180 lbf @ 0 psi

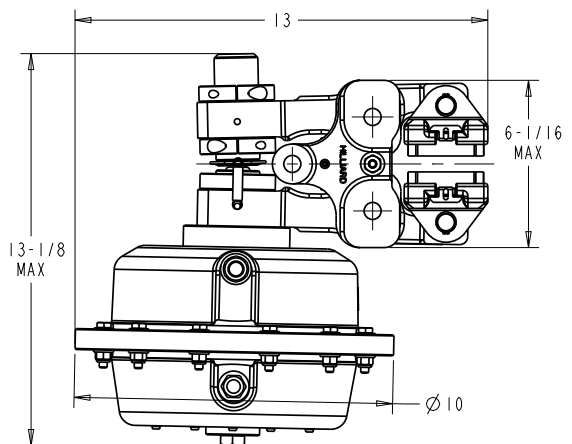

A300-T300 SA

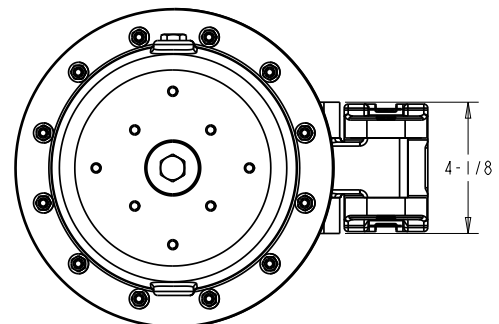

All dimensions are nominal in inches.

SPRING-APPLIED/PNEUMATIC RELEASED

A400

The **A400** is an arm style caliper brake designed to accept a large selection of Hilliard thrusters. The A400 requires a minimum disc diameter of 24" and is offered in 2 sizes to accommodate a 1" and 1-1/2" thick disc. The design of the caliper allows the user to quickly convert between right and left handed designs eliminating the need for multiple part numbers.

BRAKE TYPE:

A400-T300 SA

INDUSTRIES/APPLICATIONS:

- DRAGLINES
- MINING CONVEYORS
- MARINE
- GENERAL MACHINERY
- AMUSEMENT RIDES

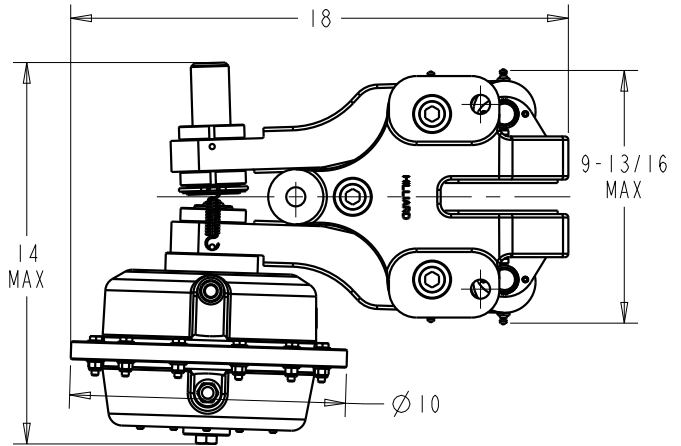

A400-T300 SA

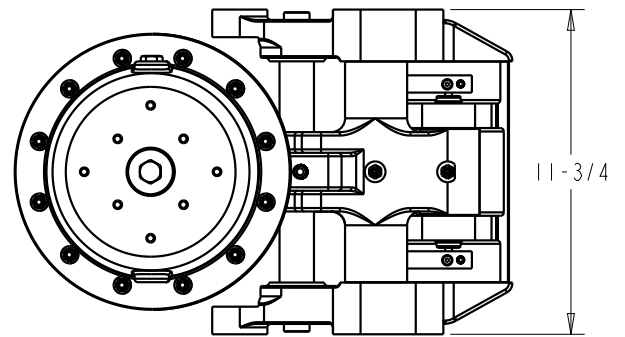

Max Braking Force 5580 lbf @ 0 psi

SA Thruster

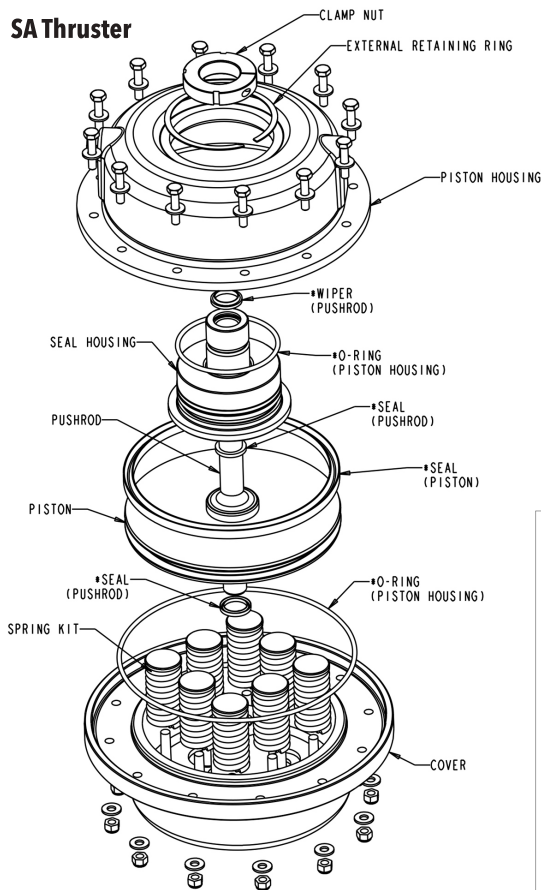

* RECOMMENDED SPARE PART (SEALS & O-RINGS AVAILABLE AS A KIT)

SA Thrusters

The SA thruster is a failsafe thruster that is spring applied pneumatically released. The spring applied thrusters are offered in multiple sizes to meet the needs of our customers.

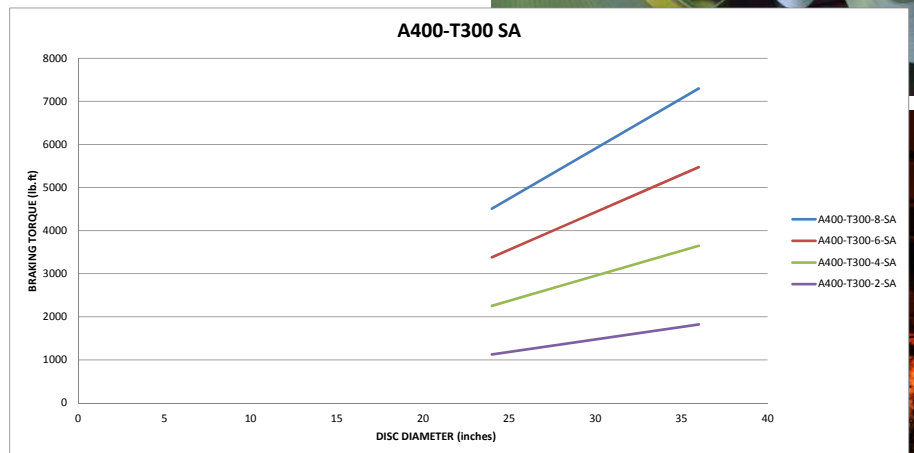
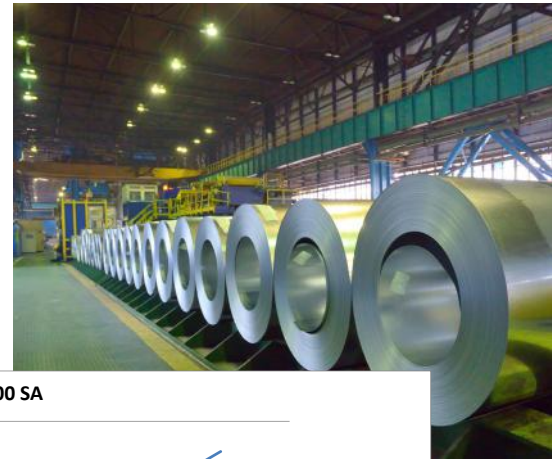

All dimensions are nominal in inches.



Caliper Brakes

SPRING-APPLIED/PNEUMATIC RELEASED

A400

The **A400** is an arm style caliper brake designed to accept a large selection of Hilliard thrusters. The A400 requires a minimum disc diameter of 24" and is offered in 2 sizes to accommodate a 1" and 1-1/2" thick disc. The design of the caliper allows the user to quickly convert between right and left handed designs eliminating the need for multiple part numbers.

BRAKE TYPE:

A400-T400 SA

INDUSTRIES/APPLICATIONS:

- DRAGLINES
- MINING CONVEYORS
- MARINE
- GENERAL MACHINERY
- BUCKET ELEVATORS
- SKIP HOISTS

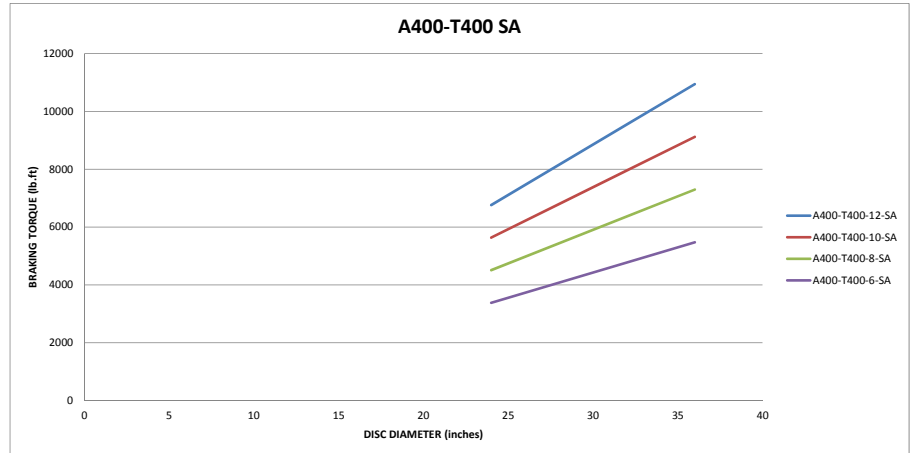

Max Braking Force 8366 lbf @ 85 psi

(This thruster is only to be used on the A400 caliper)

SA Thruster

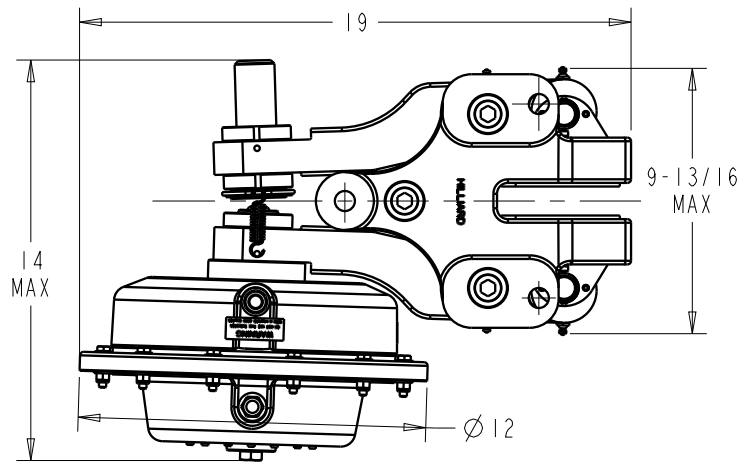
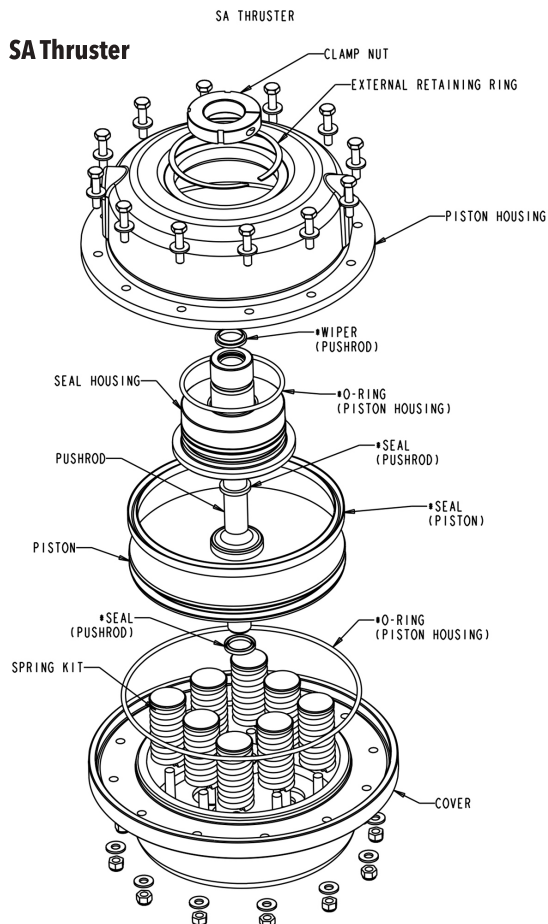

A400-T400 SA

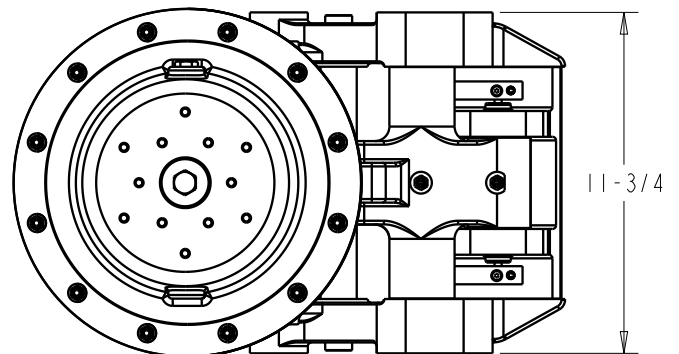

All dimensions are nominal in inches.

• RECOMMENDED SPARE PART (SEALS & O-RINGS AVAILABLE AS A KIT)

HYDRAULIC APPLIED/SPRING RELEASED

A300

The **A300** is an arm style caliper brake designed to accept a large selection of Hilliard thrusters. The A300 requires a minimum disc diameter of 12" and is offered in 4 sizes to accommodate a 1/2", 1", 1-3/16", and 1-1/2" thick disc. The design of the caliper allows the user to quickly convert between right and left handed designs eliminating the need for multiple part numbers.

BRAKE TYPE:

A300-T300 HS

INDUSTRIES/APPLICATIONS:

GENERAL MACHINERY
CRANE BRIDGE DRIVES
MARINE PROPULSION

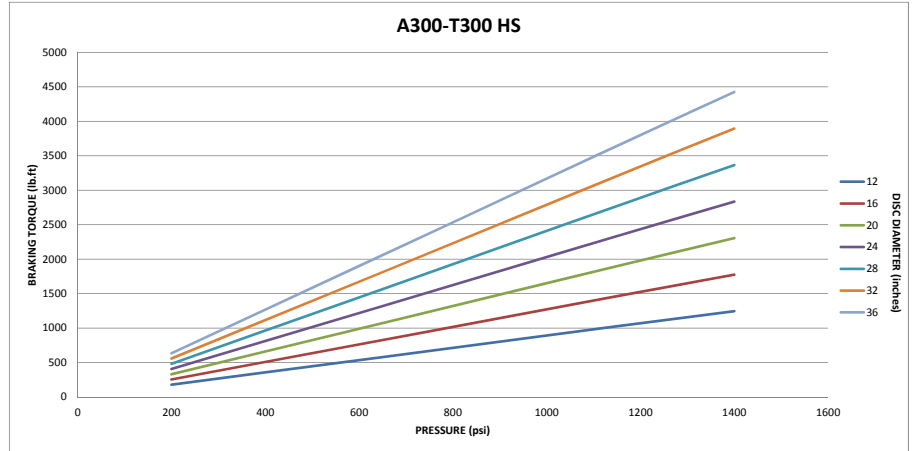

Max Braking Force 3200 lbf @ 1400 psi

HS Thrusters

The HS thruster is a direct applied thruster that is hydraulically applied spring released.

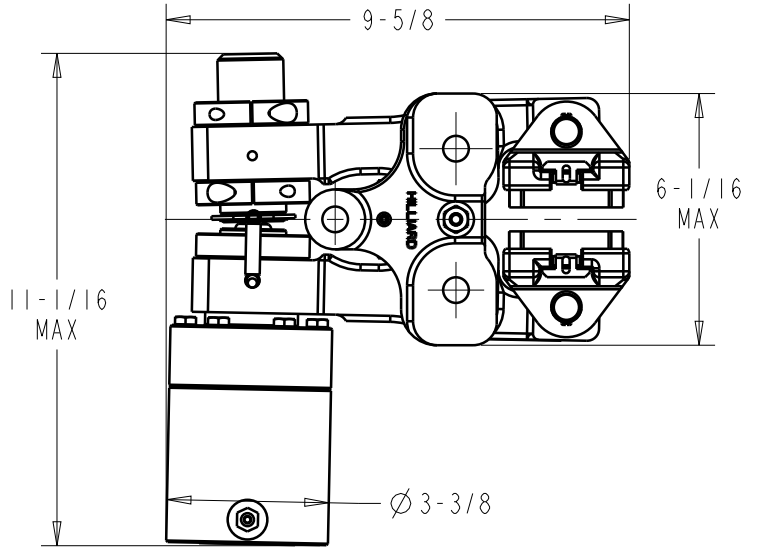
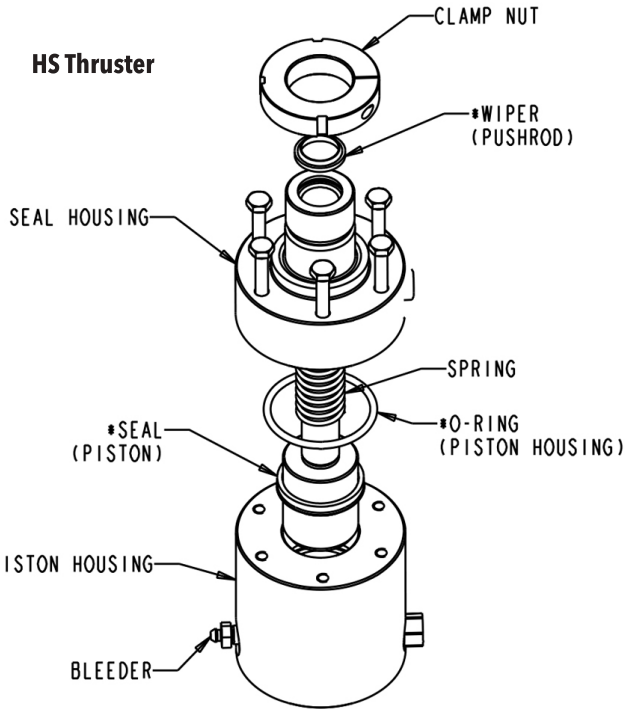

A300-T300 HS

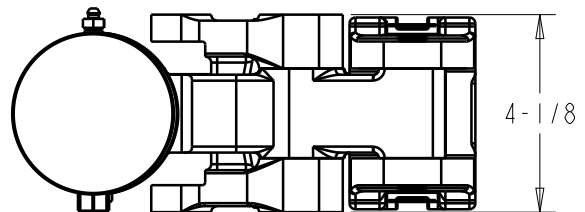

* RECOMMENDED SPARE PART (SEALS & O-RINGS AVAILABLE AS A KIT)

All dimensions are nominal in inches.

Caliper Brakes

HYDRAULIC APPLIED/SPRING RELEASED

A400

The **A400** is an arm style caliper brake designed to accept a large selection of Hilliard thrusters. The A400 requires a minimum disc diameter of 24" and is offered in 2 sizes to accommodate a 1" and 1-1/2" thick disc. The design of the caliper allows the user to quickly convert between right and left handed designs eliminating the need for multiple part numbers.

BRAKE TYPE:

A400-T400 HS

INDUSTRIES/APPLICATIONS:

MARINE PROPULSION
GENERAL MACHINERY
CRANE BRIDGE DRIVES

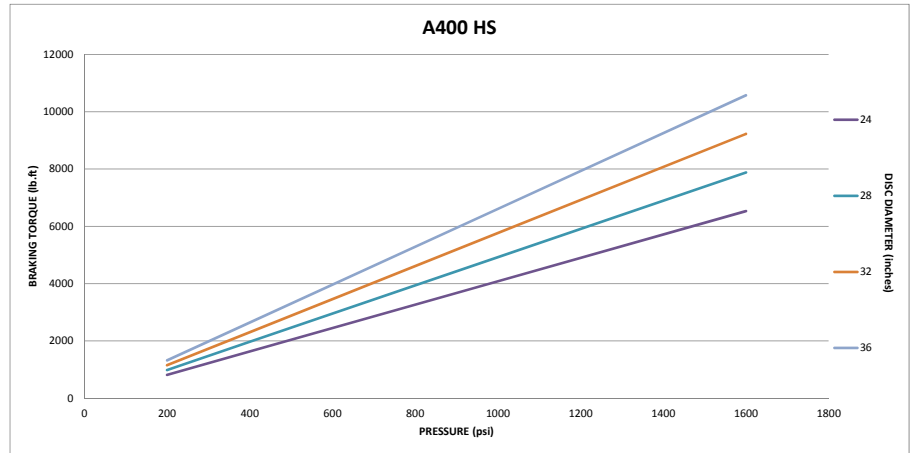

Max Braking Force 8081 lbf @ 1600 psi

(This thruster is only to be used on the A400 caliper)

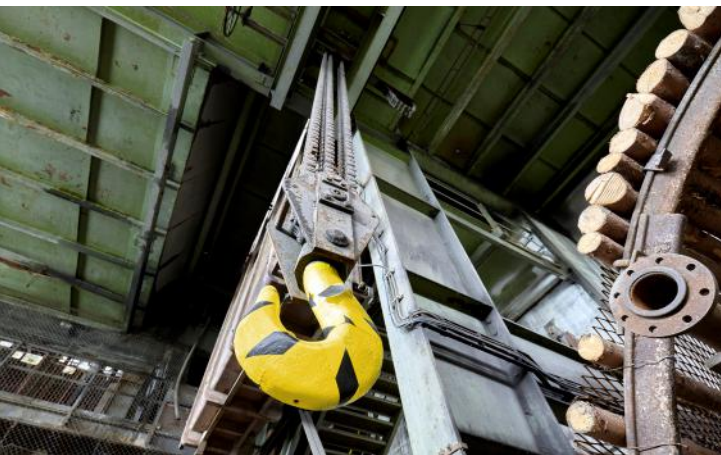

A400-T400 HS

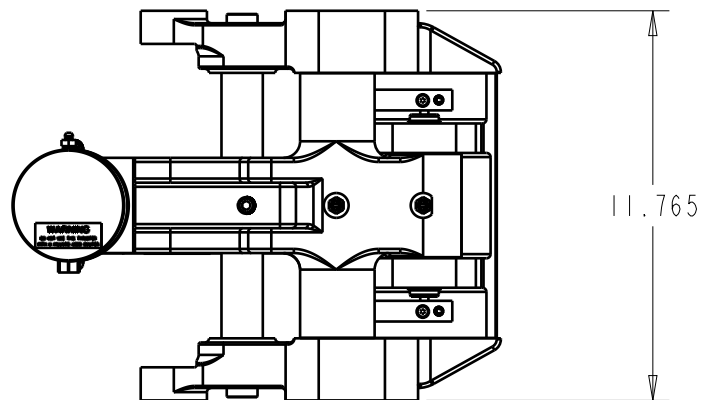
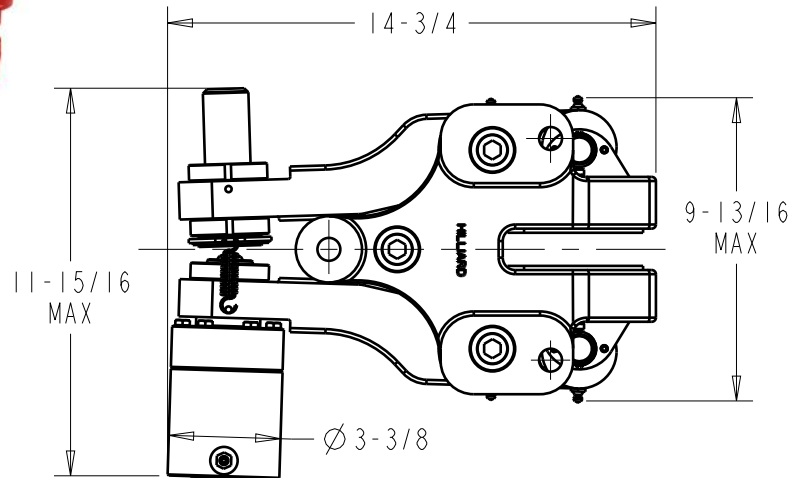

All dimensions are nominal in inches.

SPRING-APPLIED/HYDRAULIC RELEASED

A300

The **A300** is an arm style caliper brake designed to accept a large selection of Hilliard thrusters. The A300 requires a minimum disc diameter of 12" and is offered in 4 sizes to accommodate a 1/2", 1", 1-3/16", and 1-1/2" thick disc. The design of the caliper allows the user to quickly convert between right and left handed designs eliminating the need for multiple part numbers.

BRAKE TYPE: A300-T300 SH

INDUSTRIES/APPLICATIONS:

GENERAL MACHINERY
BARGE UNLOADERS
RAIL CAR DUMPERS
RAIL CAR POSITIONERS

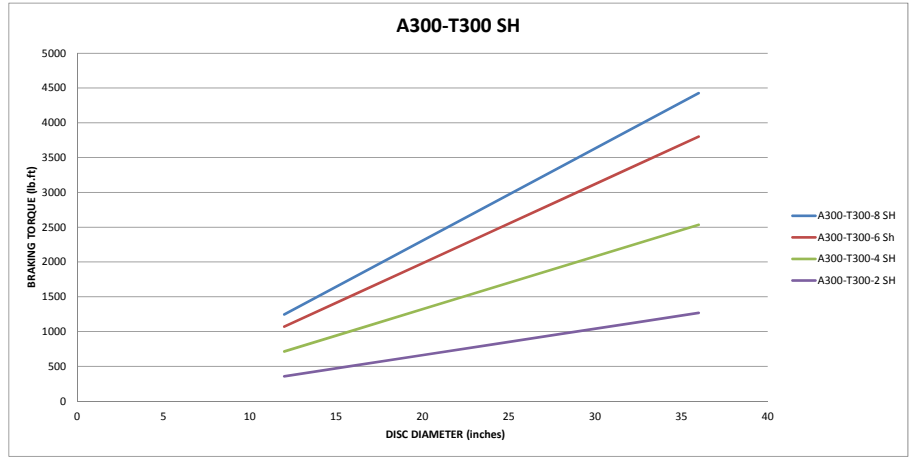

SH Thruster

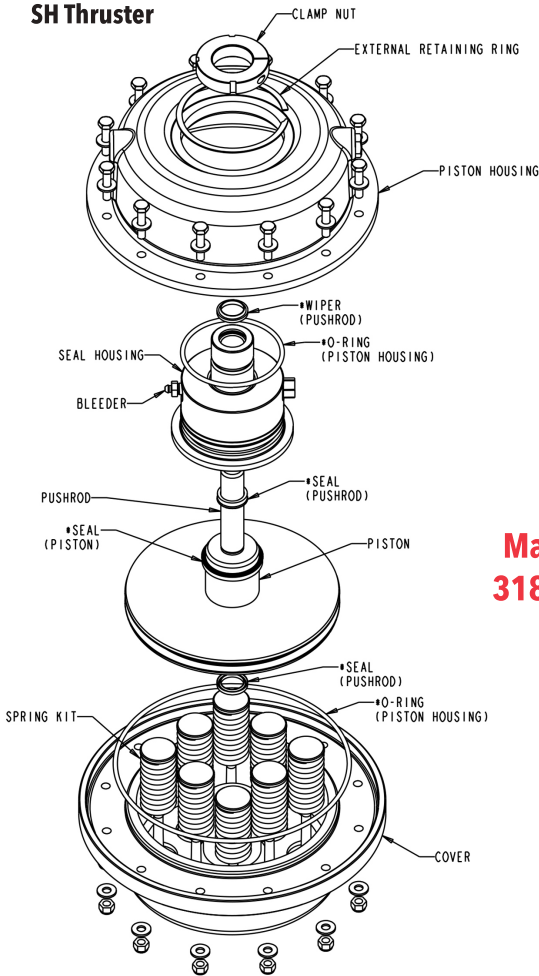

**Max Braking Force
3180 lbf @ 1450 psi**

SH Thrusters

The SH thruster is a failsafe thruster that is spring applied hydraulically released. The spring applied thrusters are offered in multiple sizes to meet the needs of our customers.

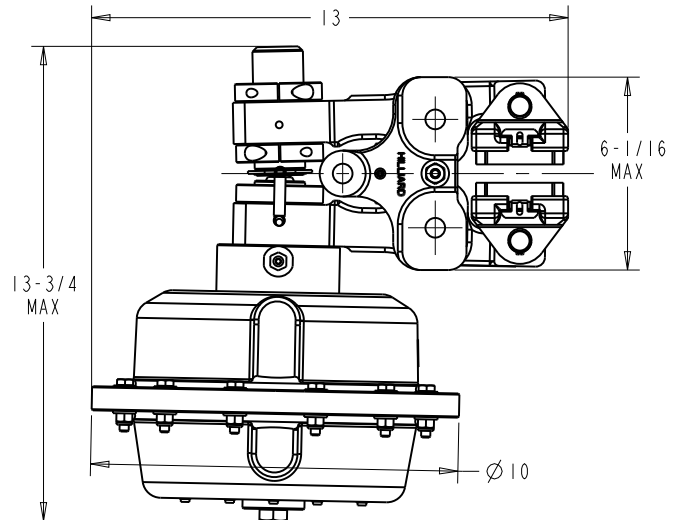

A300-T300 SH

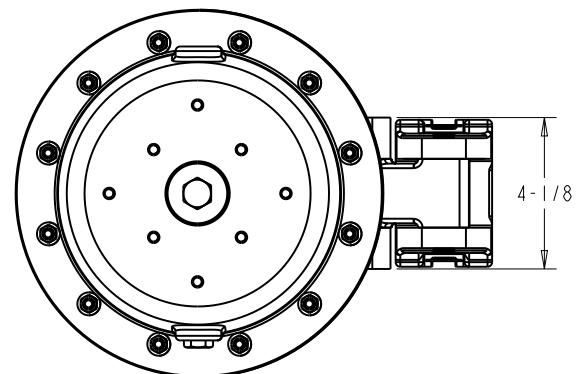

All dimensions are nominal in inches.

* RECOMMENDED SPARE PART (SEALS & O-RINGS AVAILABLE AS A KIT)

Caliper Brakes

SPRING-APPLIED/HYDRAULIC RELEASED

A400

The **A400** is an arm style caliper brake designed to accept a large selection of Hilliard thrusters. The A400 requires a minimum disc diameter of 24" and is offered in 2 sizes to accommodate a 1" and 1-1/2" thick disc. The design of the caliper allows the user to quickly convert between right and left handed designs eliminating the need for multiple part numbers.

BRAKE TYPE:
A400-T300 SH

INDUSTRIES/APPLICATIONS:

- DRAGLINES
- MINING CONVEYORS
- MARINE WINCHES
- GENERAL MACHINERY

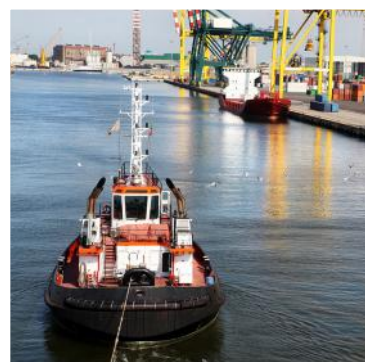
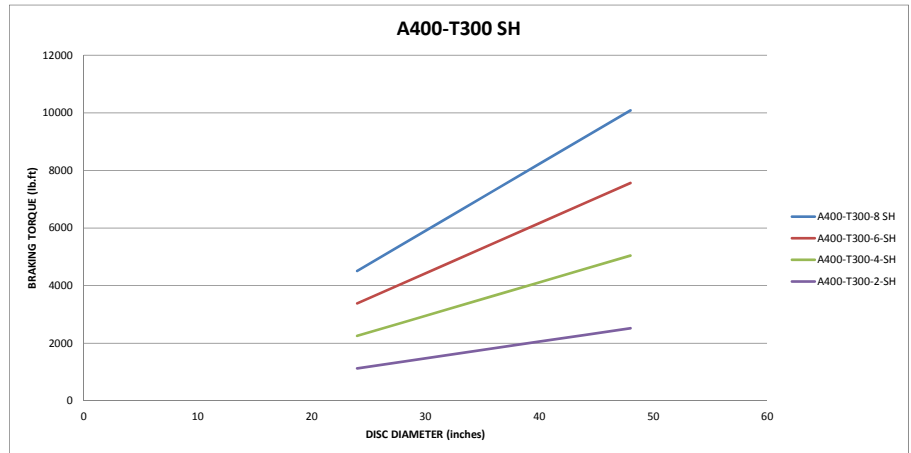

Max Braking Force 5580 lbf @ 1720 psi

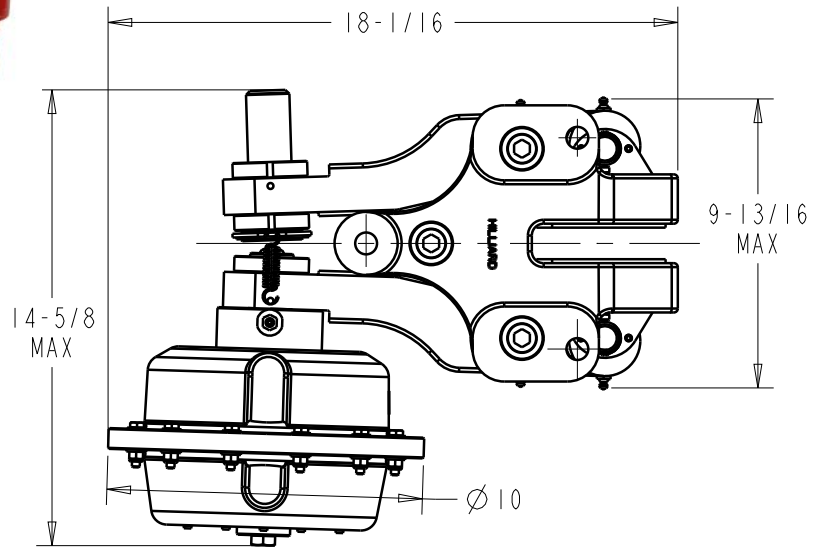

A400-T300 SH

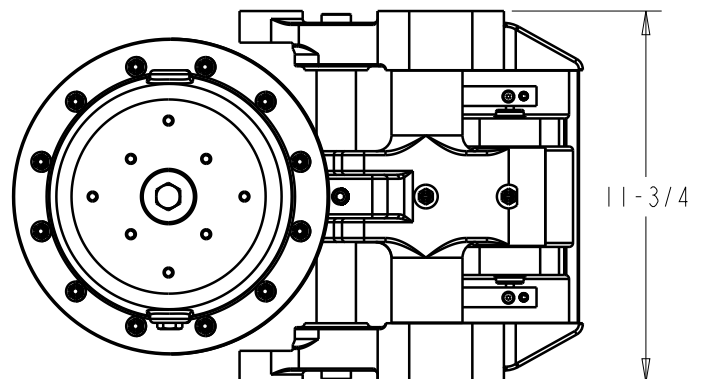

All dimensions are nominal in inches.

SPRING-APPLIED/HYDRAULIC RELEASED

BRAKE TYPE:

A400-T400 SH

INDUSTRIES/APPLICATIONS:

- DRAGLINES
- MINING CONVEYORS
- MARINE WINCHES
- GENERAL MACHINERY



SH Thruster

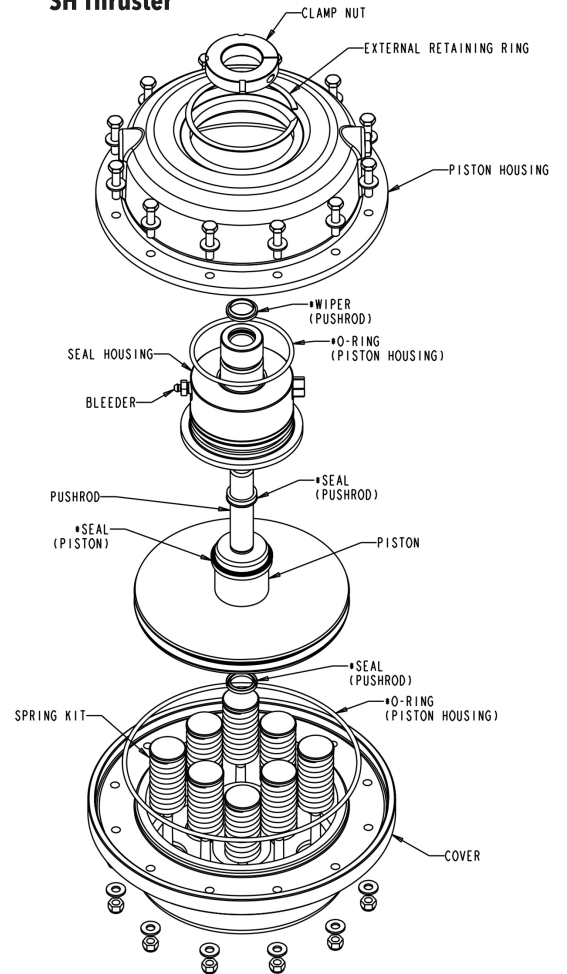

* RECOMMENDED SPARE PART (SEALS & O-RINGS AVAILABLE AS A KIT)

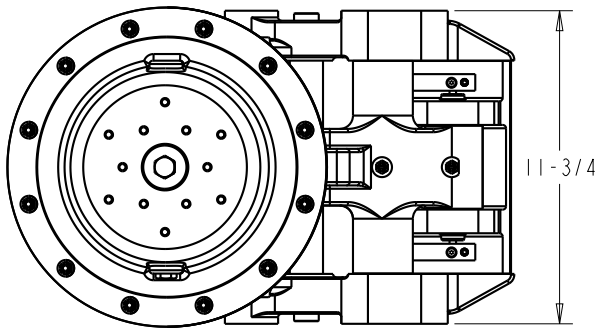
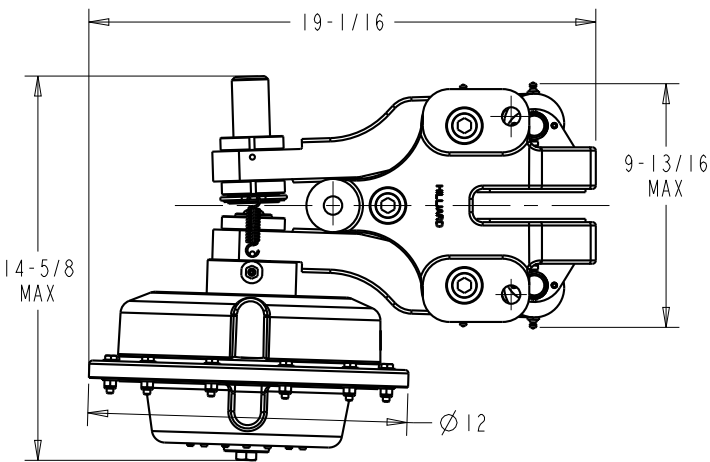

A400-T400 SH

All dimensions are nominal in inches.

Max Braking Force 8366 lbf @ 1875 psi

(This thruster is only to be used on the A400 caliper)

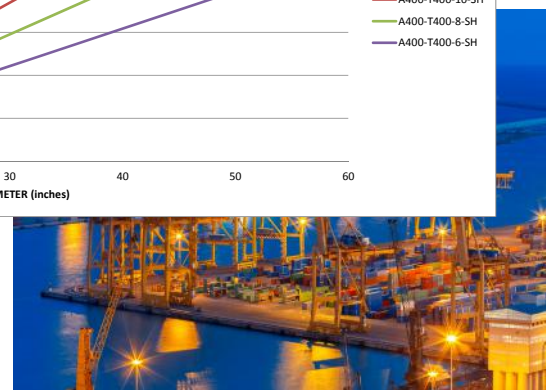
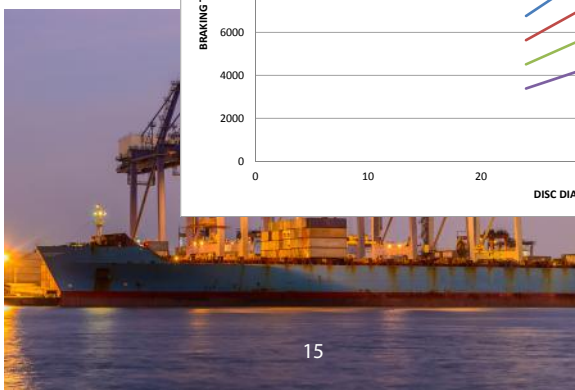
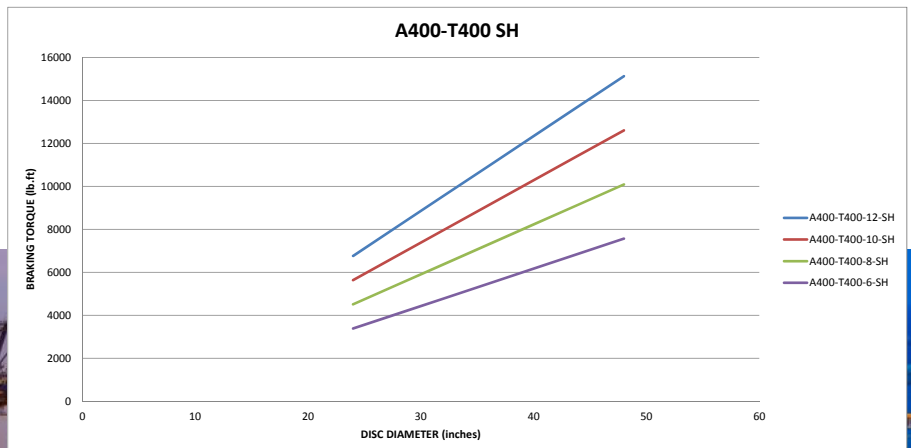

Electric Brakes

BRAKE TYPE:

MK GUIDE RAIL BRAKE

The Hilliard **MK Guide Rail Brake** is designed for use on elevators, conveyors, cranes, or other devices requiring a spring-applied electromagnetically released brake. The patented MK brake can be applied to a guide rail or a brake disc. It is unique in that it is direct acting with only one moving part. The brake incorporates an electromagnetic coil that uses a voltage dropping circuit to minimize current draw and heat when the brake is released. Shipped with manual release bolts for easy assembly to the rail or disc, it can also be equipped with a manual release mechanism for a momentary release of the brake with a standard open-end or socket wrench.

INDUSTRIES/APPLICATIONS:

ELEVATORS
 ESCALATORS
 AMUSEMENT RIDES
 PEOPLE MOVERS

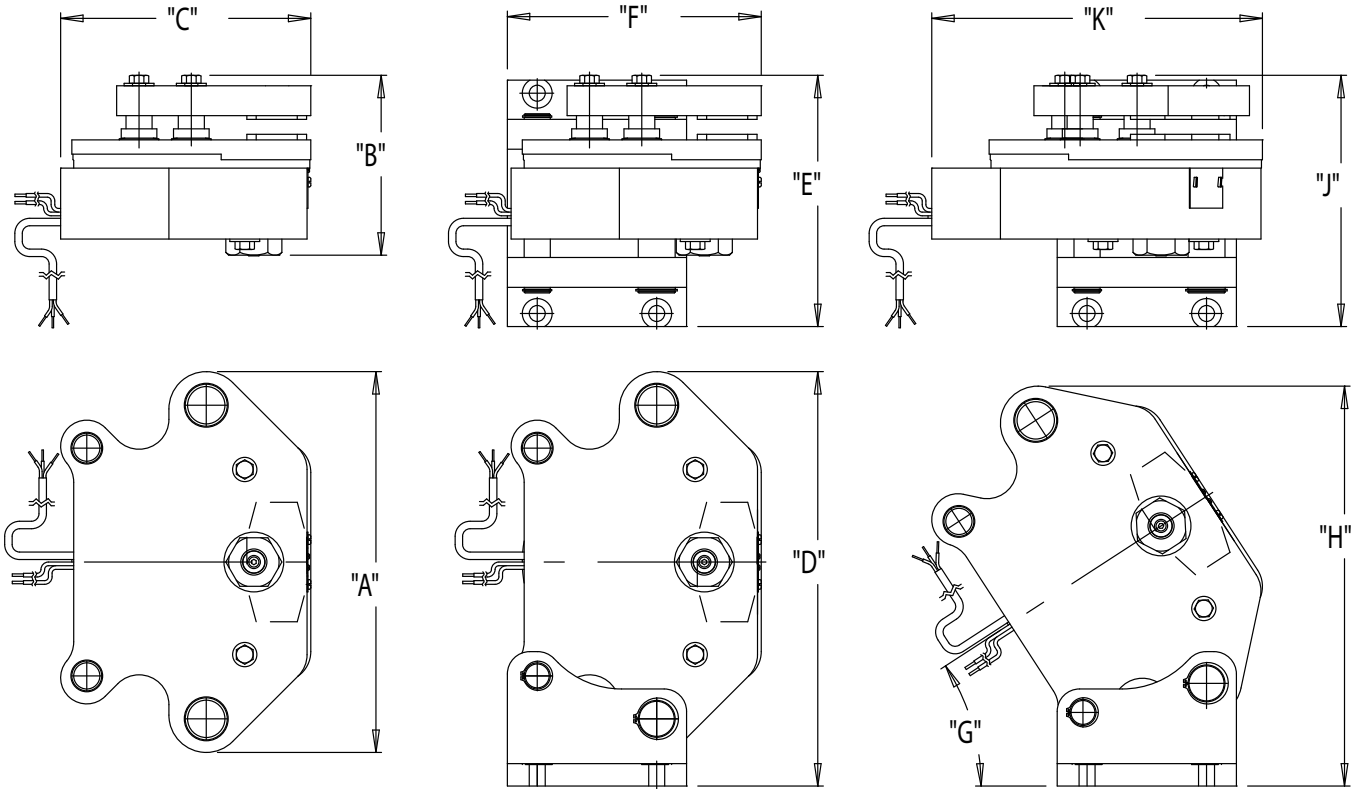

Pin Mounting

Base Mounting Horizontal

Base Mounting Angle

APPROXIMATE ENVELOPE DIMENSIONS (INCHES):

Brake Type	A	B*	C	D	E*	F	G	H	J*	K	Weight
MK-350	7.50	4.95	5.44	8.31	6.82	5.44	30	8.13	6.82	6.94	25 lb
MK-750	10.13	6.00	7.25	11.31	9.00	7.25	32	11.25	9.00	9.63	50 lb
MK-1400	13.50	6.82	8.75	14.63	8.94	8.75	33	14.00	8.94	11.56	80 lb
MK-4800	21.50	10.18	16.50	23.00	13.69	16.50	28	22.56	13.69	18.88	325 lb

All dimensions are nominal in inches. *Based on 1/2 in. Rail or Disc.



BENEFITS:

- Designed for holding duty and emergency stopping
- Manual release mechanism automatically reapplies the brake when force is removed
- Equipped with a microswitch for monitoring brake status
- Can be configured for various rail or disc thickness
- Easy to install - equipped with manual release bolts
- Can be adjusted for wear by adding shims behind the brake pads
- Mounted on pins allowing for axial movement



DATA:

Brake Type	Braking Force (lb)	Release Voltage (vdc)	Holding Voltage (vdc)	Min Disc Diameter (in)	Min Rail Depth (in)
MK-350	350	210	100	6	1.50
MK-350	250	100	100	6	1.50
MK-350	150	100	100	6	1.50
MK-750	750	210	100	10	2.50
MK-750	525	100	100	10	2.50
MK-750	400	100	100	10	2.50
MK-1400	1400	210	100	12	3.00
MK-1400	1025	100	100	12	3.00
MK-1400	865	100	100	12	3.00
MK-4800	4800	210	100	20	4.75
MK-4800	3600	100	100	20	4.75
MK-4800	2400	100	100	20	4.75

BRAKE TYPE:

ELECTRIC BRAKE

SPRING-APPLIED/ELECTRIC RELEASED



Hilliard **Electric Brakes** provide positive stopping and reliable holding of rotating devices on demand – every time.

Spring engaged when current is interrupted and electromagnetically released when voltage is applied, these brakes are designed for maximum flexibility and long, dependable service.

Each brake has an easy-to-adjust wear bolt to compensate for friction surface wear, and extend the life of the brake.

The ideal complement to Hilliard's full line of motion control products, they are available in a variety of sizes, voltages, and torque ratings.

INDUSTRIES/APPLICATIONS:

ELEVATORS
 ESCALATORS
 AMUSEMENT RIDES
 PEOPLE MOVERS



Power Units: Brake Boss™

BBH1 POWER UNIT

The **H1 Power Unit** is Hilliard's base model that includes on/off and ramped braking modes. There are many options available to customize the system to the specific needs of the application.

- Low cost alternative
- Integral manifold mounting
- Heavy duty pump with failsafe design



INDUSTRIES/APPLICATIONS:

MARINE/SHIPPING
ENERGY/WIND
CRANES/HOISTS
STEEL/METAL



BBH2 POWER UNIT

The Hilliard **H2 Power Unit** incorporates an engineered hydraulic circuit to control the brake torque during a typical stop. Large capacity hydraulic accumulators provide additional volume for precise control of brake pressure.

INDUSTRIES/APPLICATIONS:

LIFTS/ELEVATORS
ENERGY/WIND
RAIL/CONVEYORS

- Controlled braking mode
- Fully enclosed in NEMA 4 cabinet
- High pressure filtration ensures trouble free operation
- Equipped with manual overrides and a hand pump for brake operation during power outage
- Each power unit is tested before it leaves The Hilliard Corporation's facility



BBH3 POWER UNIT

The **H3 Power Unit** is Hilliard's most advanced Brake Control System. PID Loop Control monitors speed and continuously adjusts brake pressure to follow a preselected Start/Stop profile for typical applications. However, this power unit can be configured to accept other signals based on the application. For instance, the H3 can be configured to accept a 4-20 mA signal to control tension in a cable.

INDUSTRIES/APPLICATIONS:

RAIL/CONVEYORS
MARINE/SHIPPING
WIND ENERGY

- Controls start time on applications with high overhauling load conditions
- Controls stop time, independent of load and speed
- UPS battery backup to make a controlled stop during power failure
- Superior belt tension management for long conveyors or conveyors with horizontal and vertical curves
- On-board 5.5" color display for fault diagnostics with alarms that interface with the customer's PLC
- Adjustments can be made by the user to achieve the desired stopping sequence. Each power unit incorporates customized settings based on the customer's requirements for torque and is tested for functionality before it leaves Hilliard's facility.





INDUSTRIES/APPLICATIONS:
GRINDING MILLS

BBH4 POWER UNIT

The **H4 Power Unit** is designed for use with brakes that require pressures over 3,000 PSI. These power units are highly customizable, allowing the customer to specify what type of component is used for many of the items in the system.

- On/Off and ramped braking
- Customizable components include but are not limited to the motor, electrical panel, RTD, and pressure transmitter
- Bilingual labels as required
- An isolated hand pump is installed for use during power outages
- High pressure filters work on the supply and return side to ensure system integrity
- Every system is tested before it ships to verify the functionality of all equipment supplied
- Hydraulic manifold and valving are contained in a lockable enclosure for protection against environmental contamination and tampering from untrained employees
- Operator interface included on the electrical panel for local control, brake status monitoring and visual alarm status



Brake Discs & Hubs

Hilliard offers a comprehensive range of standard **Brake Discs**, manufactured from either ductile iron castings or carbon steel. Stainless steel and other special materials are also available. Standard disc diameters range from 6 inches to 54 inches, with other sizes supplied to order. Discs are bored and drilled to fit Hilliard standard Hubs, meeting customer specifications.

Hilliard standard **Disc Hubs** are supplied with parallel or tapered bores and keywayed to accommodate customer requirements. Hubs are manufactured from either iron or steel. Special hubs with keyless locking devices are also offered.

Standard and custom **Mounting Brackets** are offered for use with all Hilliard brake models.

Mounting Brackets

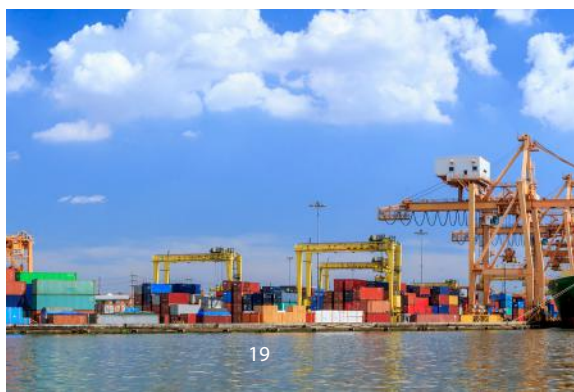
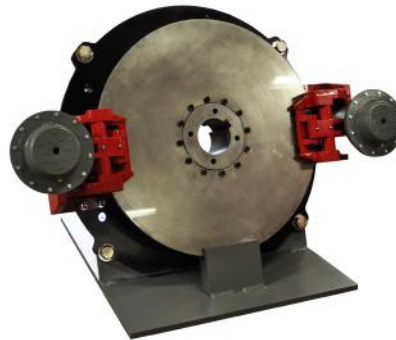

SINCE
1905

HISTORY *of* EXCELLENCE

The Hilliard Corporation solves problems. Based on extensive knowledge of motion control and filtration technologies, we make thousands of unique products, reaching markets globally.

Serving the needs of both small businesses and Fortune 500 companies, Hilliard products are found all over the world. We offer a broad line of motion control products, oil-filtration and reclaiming equipment, and plate and frame filter presses used in the food industry. We also manufacture starters for industrial gas and diesel engines and gas turbines. Our filtration systems are sold under the trade names of HILCO* and Star* Filters.

Our products are designed, manufactured, and sold according to our customer's applications. As a result, we have a large portfolio of custom engineered products that can be modified to meet new applications. At Hilliard, we embrace the challenge of product development.

With over 500,000 square feet and more than 500 highly skilled employees, we are able to meet desired requirements cost-competitively, even for short runs. Our experienced technical staff values craftsmanship, manufacturing efficiency, and responsiveness.

In order to meet customer requirements, improve quality, and increase efficiency, Hilliard is continuously investing in new equipment and technologies.

In fact, we measure Hilliard's success based on our customers' ongoing satisfaction with our product and associated services. We are proud of our product reliability and durability. We often collaborate with customers in developing solutions that are integral to their product's profitable niche in the market place.

Built in America... Made for the World

HilliardBrakeSystems.com



YOUR LOCAL REPRESENTATIVE:



The Hilliard Corporation
100 West Fourth Street
Elmira, New York 14902-1504 USA
PHONE: 607.733.7121
FAX: 607.737.1108
www.hilliardbrakesystems.com
hilliard@hilliardcorp.com

HBS-1
08/16-SBC